

"MVR" SERIES Mechanical Truck Restraint Detail

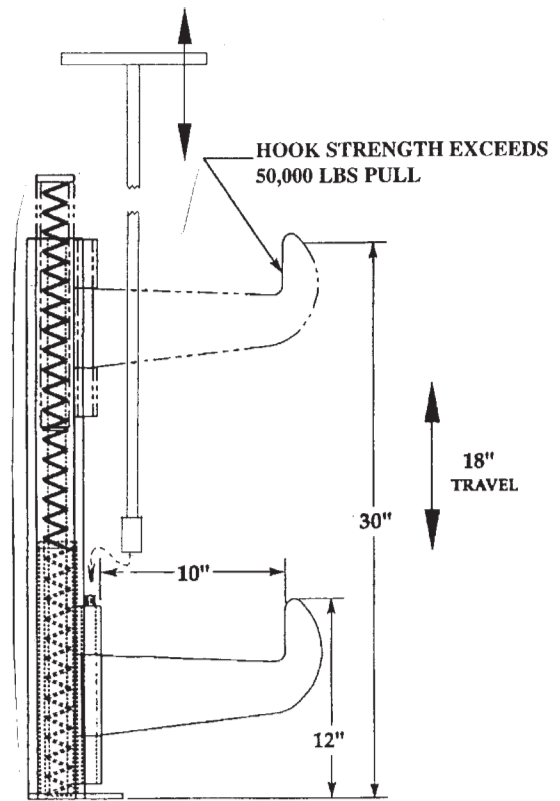

DRAWN: MVR	SIZE: B	FSCM NO. N/A	DRAWING NUMBER: MECTR	REV. A
ISSUED: J.M.G.	SCALE: 1/1	DATE: 5/2/96	SHEET: 1 of 3	
UNLESS OTHERWISE SPECIFIED: DIMENSIONS ARE IN INCHES TOLERANCES				
Inch Dimension	Decimal Dimension	Angles		
1/32"	.XX .05	.05°		
	.XXX .010			

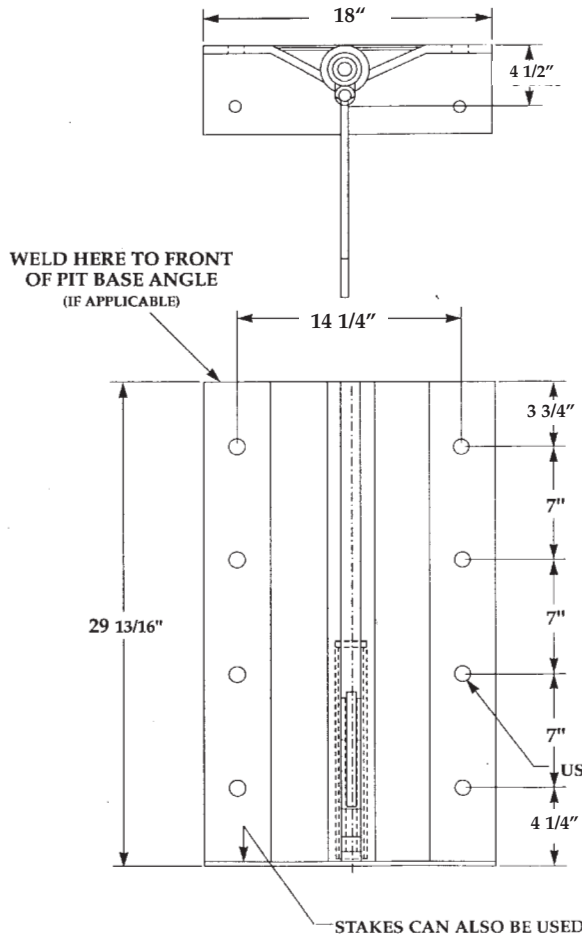

NOTES

JOB

P.O. Box 338 • Spring Hill, Tennessee 37174
 931/486-2296 • 800/251-3382 • Fax: 931/486-0316
 www.pioneerleveler.com

"MVR" Series Mechanical Truck Restraint Submittal Drawing

06/06

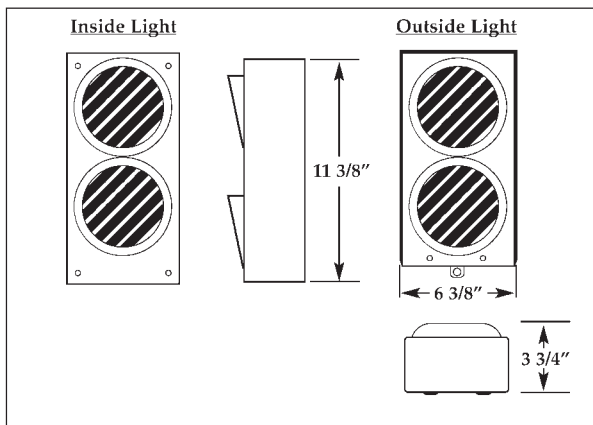
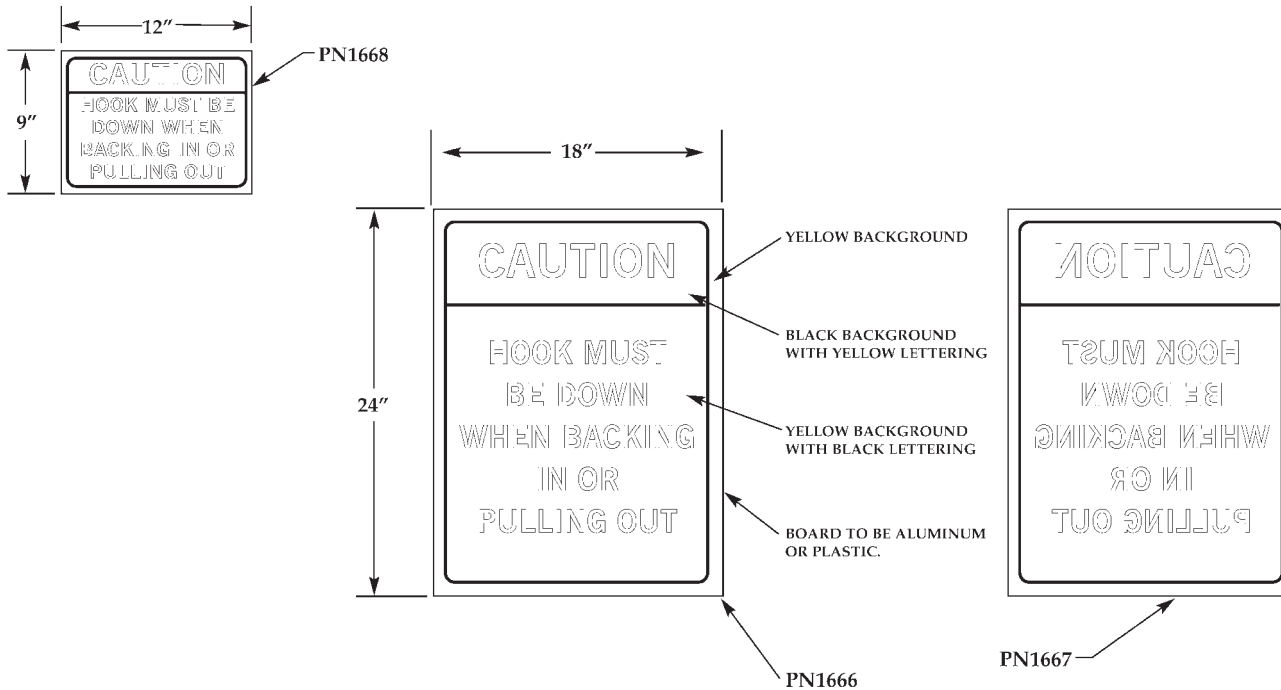

OPTIONAL DRIVER WARNING SIGNS FOR TRAFFIC DOCK LIGHT PACKAGE



STANDARD FEATURES

- Semi-automatic unit provides in excess of 50,000 lbs. restraining force.
- Wide 12"-30" operating range
- Captures and holds all legal ICC bars
- Non-impact operation — designed to meet 1998 ICC regulations
- Positive contact hook automatically floats up or down with trailer
- Exclusive pivoting hook allows for debris or snow removal within 4" of dock face.
- Bolt hole pattern designed for optimal holding force.
- Low maintenance
- Complete inside/outside sign package included
- Approximately one (1) hour installation time (not including electrical wiring)

OPTIONAL FEATURES

- Highly visible inside/outside manually operated light system with safety signs
- Automatic light system with safety signs
- Steel mounting plate for new construction
- Steel blockouts for bumper projections greater than 4" including edge-of-dock levelers
- Template for pre-mounting attachment bolts



P.O. Box 338 • Spring Hill, Tennessee 37174
 931/486-2296 • 800/251-3382 • Fax: 931/486-0316
www.pioneerleveler.com