

P2000 Series Mechanical Pit Levelers



Rugged. Dependable. PIONEER.

P.O. Box 338 • Spring Hill, Tennessee 37174 • 1-800-251-3382 • fax: 931-486-0316 • www.pioneerleveler.com



WARNING

DO NOT install, operate or service product unless you have read and understand the Safety Procedures, Warnings, Installation and Operating instructions contained in this manual. Failure to do so could result in serious injury and/or death.

Safety Procedures



WARNING: Read and understand all safety practices and operating instructions Before installing, operating or servicing the dock leveler. Failure to follow the safety practices and operating instructions may result in property damage, serious bodily injury and/or death.

If you do not understand the safety procedures or the instructions, ask your supervisor to explain the safety procedures and/or teach you how to use the dock leveler.



CAUTION: The installer and/or operator **MUST** be very familiar with the operation, function and various parts of the PIONEER Pit Leveler **PRIOR** to installation and/or operation. If this is not the case, it is **IMPERATIVE** that the installer and/or operator read, and fully understand, the entire contents of this manual. **Be certain to read and understand all warning and caution statements contained in this manual prior to any installation, operation or servicing of this unit.**

- 1 Do not operate this equipment while under the influence of drugs or alcohol.
- 2 Do not stand in the driveway between the dock leveler and a truck backing or pulling away.
- 3 Be sure the truck wheels are chocked, or the truck is held in place by a restraining device, before attempting to load or unload the truck.
- 4 Do not use the dock leveler if it looks broken or does not seem to work right. Lock out/tag out the defective equipment. Tell your supervisor immediately.
- 5 Do not operate the leveler with equipment, material or people on the platform and/or lip or in front of the leveler.
- 6 Be certain that equipment, material or people are not on the dock leveler before allowing a truck to pull out.
- 7 Keep clear of the dock leveler when it is moving. Never place your hands, arms, feet, or legs in the position where a moving dock leveler or a moving load could cause injury. **If in doubt, do not do it!**
- 8 If the dock leveler is not working properly, using the operation instructions in this manual, **do not use the dock leveler.** Contact your authorized PIONEER representative.
- 9 Never attempt to work under the dock leveler, for service or repair, without proper placement of maintenance strut.
- 10 Damage to the dock leveler, personal injury or death can result from abuse and/or negligent use of this equipment.
- 11 If you have any questions, or if a malfunction occurs which is not understood, ask your supervisor to contact your authorized PIONEER representative for assistance **PRIOR** to attempting any corrective measures.



THIS IS THE SAFETY ALERT SYMBOL. IT IS USED TO ALERT YOU TO POTENTIAL PERSONAL INJURY HAZARDS. OBEY ALL SAFETY MESSAGES THAT FOLLOW THIS SYMBOL TO AVOID POSSIBLE INJURY AND/OR DEATH.



WARNING

INDICATES A POTENTIALLY HAZARDOUS SITUATION WHICH, IF NOT AVOIDED, COULD RESULT IN SERIOUS INJURY AND/OR DEATH.



KEEP THIS MANUAL AND ALL SAFETY PROCEDURES IN A SECURE LOCATION WITH EASY ACCESS.



WARNING! READ AND UNDERSTAND THIS ENTIRE MANUAL PRIOR TO OPERATING.



WARNING! A DOCK LEVELER CAN BE A POTENTIAL THREAT TO PERSONS AND PROPERTY, IF NOT USED PROPERLY. SAFE OPERATION IS THE RESPONSIBILITY OF THE OPERATOR.



WARNING! DO NOT ENTER THE AREA IN FRONT OF OR BELOW THE DOCK LEVELER. SERIOUS PERSONAL INJURY AND/OR DEATH MAY RESULT.



WARNING! DO NOT ATTEMPT TO INSTALL, MAKE REPAIRS OR ADJUSTMENTS. ONLY A TRAINED AND AUTHORIZED SERVICE TECHNICIAN SHOULD PERFORM REPAIRS OR ADJUSTMENTS. ONLY A QUALIFIED CONTRACTOR/SUB-CONTRACTOR SHOULD PERFORM THE INSTALLATION PROCESS. CONTACT YOUR LOCAL PIONEER DEALER FOR ASSISTANCE.

SECTION 1

INSTALLATION INSTRUCTIONS RECEIVING AND HANDLING

RECEIVING:  **WARNING**

Before installing the dock leveler, read and follow the safety procedures and the operating instructions. Failure to follow the safety procedures could result in serious injury and/or death.

Check for possible damage or missing parts immediately upon receipt of unit. Note any damage on receiving papers.

Prepare any claims against carrier if necessary.

NOTE: Damage noticed after receipt must be reported to carrier within 15 days.

Notify PIONEER of any damage or missing parts.

HANDLING:

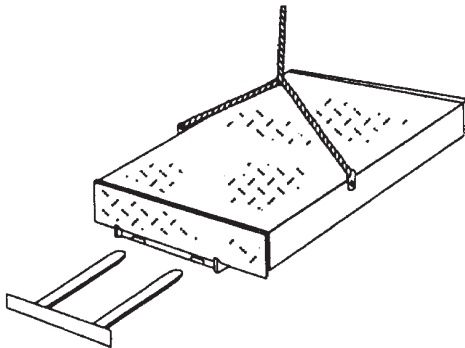

FIGURE A

Move leveler into position by using:

- chain sling inserted into upper side plate holes. (See Figure A)
- Fork lift, inserted into front fork slots;
- Fork lift, inserted into rear fork slots just below the deck.

NOTE:

Two bumpers, and weather seals, if applicable, are strapped under leveler. Handle with care to avoid damage to these components.

Contact PIONEER for chain sling assembly (Part #1700)

SECTION 1

INSTALLATION INSTRUCTIONS INSTALLATION

INSTALLATION: (Consists of 3 phases)

Pit preparation

Leveler Preparation

Leveler Installation



Caution: Before you start to install the leveler, use proper safety signs and barriers to separate the work area from the remainder of the dock.

 **WARNING**

Never allow anyone to stand on or near dock leveler when it is being lifted or placed into the pit. Failure to follow this warning can allow the dock leveler to fall, tip, or swing into people, resulting in serious injury and/or death.

"P2000" SERIES PIT DETAIL

FIGURE B – PLAN VIEW

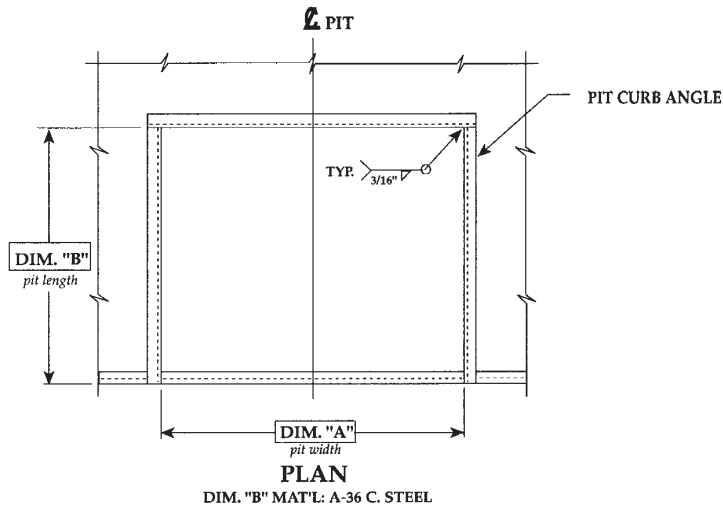

VARIABLE DIMENSIONS				
MODEL SIZE	"A"	"B"	"C"	"D"
6'W x 6'L	74"	63"	19 1/2"	20"
6'W x 8'L	74"	87"	19 1/2"	20"
6'-6" W x 6'L	80"	63"	19 1/2"	20"
6'-6" x 8'L	80"	87"	19 1/2"	20"
7'W x 6'L	85"	63"	19 1/2"	20"
7'W x 8'L	85"	87"	19 1/2"	20"
6'W x 10'L	74"	111"	19 1/2"	20"
6'-6" W x 10'L	80"	111"	19 1/2"	20"
7'W x 10'L	85"	111"	19 1/2"	20"

INSERT SPECIFIC JOB DIMENSIONS FROM CHART

--	--	--	--

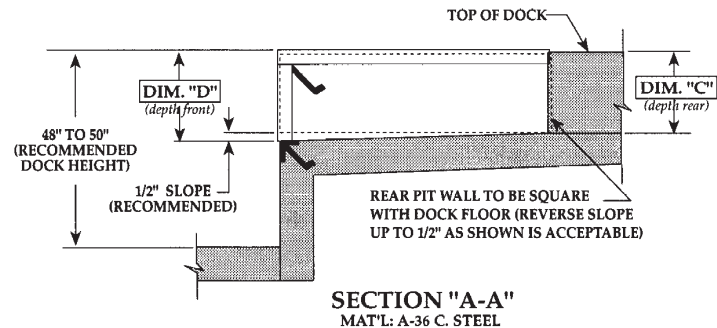
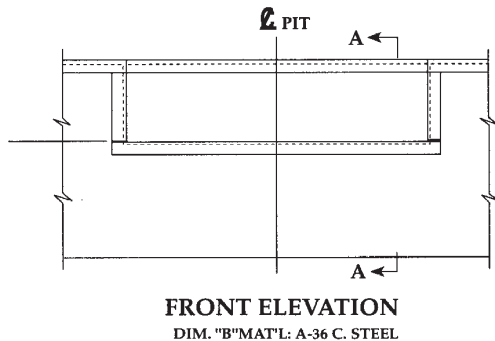

P.O. Box 338 1-888-702-1163
 Spring Hill, TN 37174 1-888-702-1164
 Fax: 931-486-0316 1-888-702-1165
www.pioneerleveler.com

NOTES

JOB

DRAWN: D.E.A.	SCALE: AS NOTED	DATE: 6/19/96	DRAWING NUMBER: PMI-2010
-------------------------	---------------------------	-------------------------	------------------------------------

TOLERANCES		
Inch Dimension =	Decimal Dimension =	Angles =
1/16"	.005	1°

SECTION 1

INSTALLATION INSTRUCTIONS PIT PREPARATION

PIT PREPARATION

1. Examine pit.
2. Measure pit dimensions. (See “Variable Dimensions” Figure B, Page 1-2)



Before welding the rear frame, cover the rear weather seal with a sheet of steel to prevent setting fire to the weather seals. Failure to do so may result in property damage.

Pit walls should be square and plumb. Clean all debris from pit. Verify that walls are square and plumb and that the floor is level in the back and on the sides of the pit.

PRE-PLACEMENT OF SHIMS:

1. Place shims in correct locations on pit floor before lowering leveler into place in pit.

Proper shim thickness will assure that deck of leveler is level with dock floor.

NOTE 1: Shims are to be placed directly under each rear frame upright, and under lip keepers. (See Figure C, Page 1-3) and (See Plan View, Page 1-2).

NOTE 2: For units with a 20” lip the lip keepers are separate. Prior to shimming, weld the angle with the lip keeper under the front base frame. (See Figure C, Page 1-3) (See Figure E, Page 1-5)

SECTION 1

INSTALLATION INSTRUCTIONS LEVELER PREPARATION

LEVELER PREPARATION

1. Position leveler directly in front of pit
2. Cut restraining band on lip.

WARNING

Be Careful of the lip falling before the lip lock is engaged. The lip plate could fall causing serious injury and/or death.

Remove band completely from leveler..

FIGURE C

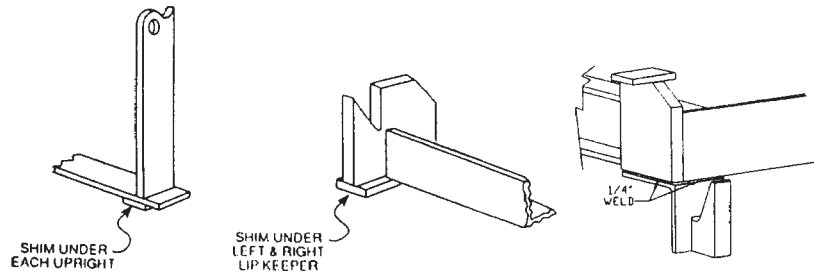
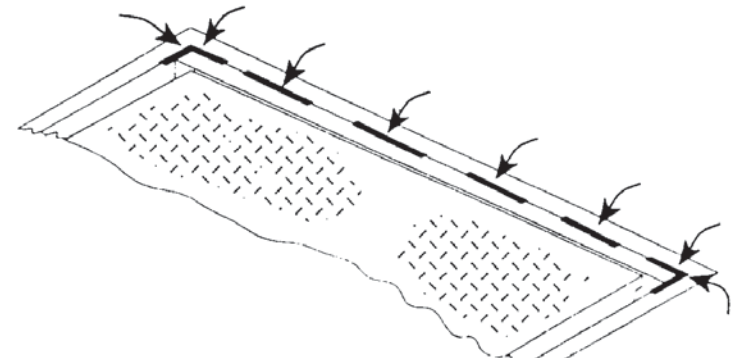

FIGURE D



SECTION 1

INSTALLATION INSTRUCTIONS LEVELER INSTALLATION

LEVELER INSTALLATION:

WARNING

DO NOT work under the dock leveler, ramp, or lip unless the maintenance strut is in place.

WARNING

Keep fingers, hands, and head away from the lip when it is released. Fingers, hands, or head could be struck by or caught between the lip and other parts of the dock leveler causing serious injury and/or death.

WARNING

Improper installation of anchoring devices or installation into aged or unsound concrete could result in serious injury and/or death.

1. Place leveler into pit opening.

Allow one inch (1") equal clearance between leveler sides and pit walls. Rear frame angle of leveler should be tight against and flush with rear curb angle for proper welding.

2. Recheck shim packs to ensure leveler is at proper height, flush with floor level, front and rear, after restraining band has been cut.

For leveler with a 20" lip — with leveler flush with dock floor locate lip keepers on frame / embedded curb angle and move upwards until lip touches bottom of keeper. Lip keeper should be located 12" toward center from each side.

Shims must be placed properly under each rear frame upright, and front lip keepers. (See Figure C, Page 1-3, for close up view and Plan View B, Page 1-2, for shim locations.)

Skip weld rear of leveler to curb angle (weld center first then ends) and front shims to leveler and curb angle. (See Figure D, Page 1-3)

3. Bring deck section of leveler to fully raised position.

To operate, pull and hold the ratchet release chain located at rear of leveler.

4. Place maintenance strut securely under leveler.

Place strut in tubes located on base & under lip.

SECTION 1**INSTALLATION INSTRUCTIONS
LEVELER INSTALLATION**

LEVELER INSTALLATION:

5. Weld all shims securely in place.

Front shims must be welded securely to frame and steel curb angle.

6. Store maintenance strut.

Walk forward onto leveler, returning it to dock level with lip in keepers.

7. Install bumpers on dock face.

Securely bolt bumpers to dock face as close to pit opening as possible. Bumpers should be flush with dock floor or 48" off ground. Raised bumpers should be supported to floor from behind.

8. Complete weld at rear of leveler.

Weld to cover approximately 50% of the length of the rear angle. Ensure welds are placed directly behind frame uprights and at ends of angle. (See Figure D, Page 1-3)

CAUTION: Before you start to install the leveler, use proper safety signs and barriers to separate the work area from the remainder of the dock.

SECTION 1

INSTALLATION INSTRUCTIONS LEVELER PREPARATION

20" LIP KEEPER INSTALLATION INSTRUCTIONS

Two separate lip keeper angles are provided with every unit that has a 20" lip. These angles are tack welded to the leveler base frame just behind the lip.

Break each one loose and set the leveler into the pit per the installation instructions in the owner's manual.

Prior to angle installation or shimming make sure that the unit is snug against the embedded curb angle at the back of the pit.

Place the lip keepers under the front base angle on either side of the unit with the top of the angle protruding out past the base 1/4" in the front and on the left for the left hand keeper and on the right for the right hand keeper. This will facilitate welding.

Fully weld the keeper angle to the base angle.

Proceed with shimming per the owner's manual.

Figure E

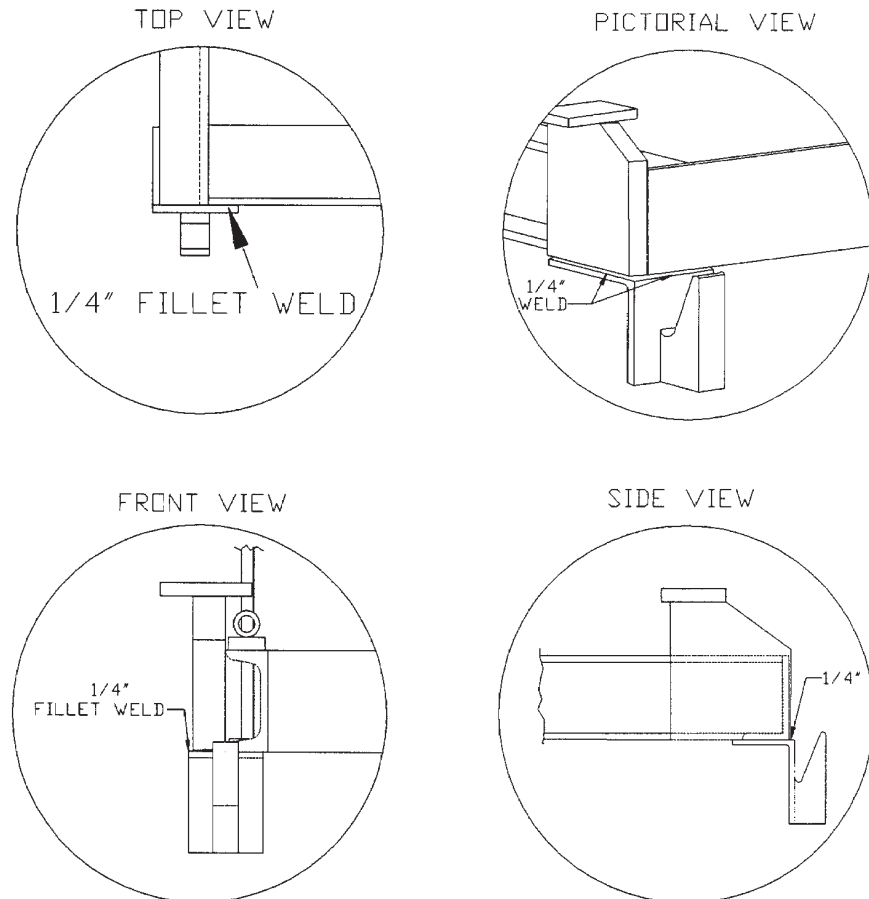

SECTION 2

OPERATING INSTRUCTIONS ABOVE DOCK OPERATION

WARNING

ALWAYS secure the vehicle with a vehicle restraint or wheel chocks before operating the dock leveler.

- * DO NOT operate leveler with anyone standing on or in front of leveler.
- * DO NOT lift the leveler by hand.
- * ALWAYS keep fingers, hands, feet, and head clear of all moving parts.

WARNING

If the lip does not fully extend, do not lift by hand. Restore leveler to dock level and try again. If lip still does not fully extend, the dock leveler requires maintenance or adjustment. Notify your supervisor. DO NOT use the leveler until it has been repaired. Failure to do so could result in serious injury and/or death.

WARNING

If the lip does not fall to the stored position, the dock leveler requires maintenance or adjustment. Notify your supervisor. DO NOT use dock leveler until it has been repaired. Failure to do so could result in serious injury and/or death.

ABOVE DOCK USE:

1. Pull firmly and hold the release ring located in rear of deck.

When deck raises and lip extends, release the ring. DO NOT release the ring until the lip is fully extended.

2. Walk forward onto deck to lower unit onto truck bed. (Truck should be secured firmly against bumpers with "Truck Restraint" or wheel chocks.)

With standard locking type lip mechanism, lock will release once lip makes firm contact with truck bed.

3. When truck departs, lip will close to pendant (not stored) position.

This action applies when truck is above dock height.

4. Walk forward onto deck until unit is returned to stored position.

In this position, lip is secure in lip keepers, and ready to receive the next truck.

SECTION 2**OPERATING INSTRUCTIONS
ABOVE DOCK OPERATION****ABOVE DOCK USE:**

5. Leveler may be recycled with truck at dock.

Pull the rear release ring in short, rapid pulls allowing deck to raise 2" – 3" above dock with lip in the closed position.

Walk forward onto leveler, returning it to dock level with lip in keepers.

This allows operator to close the truck and/or building door prior to truck departure.

SECTION 2

OPERATING INSTRUCTIONS BELOW DOCK OPERATION

BELOW DOCK USE: (WITH LIP EXTENDED)

1. Repeat steps 1 & 2 for above dock use.	
2. As you walk forward on the leveler, pull and hold the safety leg release ring located in the front of the deck plate (toward the lip).	This will pull safety legs away from the pads they would normally contact allowing unit to go below dock. When lip makes firm contact with the truck bed, release the front ring.
3. When truck departs, lip will return to pendant (not stored) position.	Lip will be in front of lip keepers, and deck will remain below floor level.
4. To recycle unit after truck departure, pull release ring in short, rapid pulls.	This action will allow the deck to raise 2" – 3" above dock floor while the lip remains in a pendant position.
5. Leveler may be recycled with <u>truck at dock.</u>	Follow Step #4 to recycle.
6. Following Step #4, walk forward onto deck until unit is returned to stored position.	Lip should be completely closed and resting in lip keepers which provide overnight security.

SECTION 2

OPERATING INSTRUCTIONS BELOW DOCK OPERATION

BELOW DOCK USE: (LIP RETRACTED FOR END LOADS)

BELOW DOCK CONTROL OPTION IS RECOMMENDED FOR THIS OPERATION:

1. Pull release ring in short rapid pulls.

Allow deck to raise 2" – 3" above dock floor. (This will raise lip out of lip keepers, without extending lip.)

2. As you walk forward on the leveler, pull the safety leg release ring located in the front of deck plate.

With Below Dock Control option, lip will be pushed out in front of keepers while safety legs are being pulled away from pads.

3. When truck departs, lip will close to pendant (not stored) position.

Lip will be in front of keepers, and deck will remain below dock.

4. To recycle unit after truck departs, pull release ring in short, rapid pulls.

Continue this until unit is 2" – 3" above dock floor.

5. Leveler may be recycled with truck at dock.

Follow Step #4 to recycle.

6. Following Step #4, walk forward onto deck until unit is returned to stored position.

Lip should be completely closed and resting in lip keepers which also provide overnight security.



CAUTION: ALWAYS SECURE LEVELER WITH LIP IN KEEPERS AND SAFETY LEGS FORWARD TO INSURE SAFE CROSS TRAFFIC USE.

ALL “P2000” SERIES LEVELERS ARE TESTED AND ADJUSTED AT THE FACTORY. HOWEVER, MINOR ADJUSTMENTS TO THE MAIN SPRINGS MAY BE REQUIRED ONCE THE UNIT IS INSTALLED. (UNITS WITH WEATHER SEALS NORMALLY REQUIRE MAIN SPRING ADJUSTMENT TO INSURE PROPER LIP EXTENSION).

 WARNING

Read and follow the safety procedures in this manual before doing any service or repair to the dock leveler. ALWAYS SECURE LEVELER WITH MAINTENANCE STRUT BEFORE CLIMBING INTO THE DOCK LEVELER PIT OR DOING ANY MAINTENANCE OR REPAIR UNDER THE DOCK LEVELER. Failure to do so could result in serious injury and/or death.

SYMPTOM:	PROBABLE CAUSE:	CORRECTION:
<p>WHEN RELEASE RING IS PULLED, DECK RAISES BUT LIP DOES NOT FULLY EXTEND AND LOCK.</p> <p>Note: With Hydra-Lip Option, lip is designed to begin closing once extended, or when truck departs. No adjustment is required. Assem. #30</p>	<p>1. Improper main spring adjustment. NOTE: On units with either lip assist or hydra lip, proper adjustment will entail a combination of adjusting the lip assist spring and possibly the main springs. (See #3 below)</p>	<p>Tighten both main spring adjustment nuts one or two rotation clockwise and re-test. Item #7 (1 1/2" socket or wrench)</p>
	<p>2. Lip lock spring is stretched.</p>	<p>Replace spring or lower spring one or two links on snubber chain. Item #22; Assem. #6</p>
	<p>3. Improper adjustment of lip assist spring (furnished as standard equipment with 18" and 20" lip lengths)</p>	<p>Tighten both hex nuts, on the lip assist rods, two (2) clockwise rotations and re-test. Item # 27. Note: The back nut, toward the rear of the leverler, is the adjustment nut. After attaining proper adjustment, hold the back nut and securely tighten the front or lock nut against the adjustment nut.</p>
	<p>4. Lip lock spring is broken or disconnected.</p>	<p>Replace broken spring and/or reconnect spring to proper chain link with “S” hook. Item #22, Assem. #6</p>
	<p>Leveler may be servicing trucks that are above the factory set service range (8' models – 12", 6' models – 8") causing lip to impact truck during upward movement.</p>	<p>Minor adjustments to service range above dock may be made in the field. Consult the local PIONEER representative or call the factory for assistance.</p>

SECTION 3**TROUBLESHOOTING**

SYMPTOM:	PROBABLE CAUSE:	CORRECTION:
(HYDRA-LIP OPTION) Lip will not close completely when truck departs.	Lip assist spring is over compressed.	Loosen both hex nuts on the lip assist rod two (2) rotations <u>counter-clockwise</u> and re-test. Item # 27
(HYDRA-LIP OPTION) Lip closes too fast when extended.	Lip assist spring is under compressed.	Tighten both hex nuts on the lip assist rod two (2) clockwise rotations and re-test. Item # 27
	Shocks are failing after years of use.	Replace with new shocks. Item # 29 (Covered by 1 year warranty)

CAUTION:

Contact your PIONEER representative or the factory if a malfunction occurs which is not understood. DO NOT attempt to correct the situation without proper information and understanding, as this may damage components and void the warranty.

 **WARNING**

BEFORE SERVICING THE DOCK LEVELER, READ AND FOLLOW ALL SAFETY PROCEDURES IN THIS MANUAL. FAILURE TO DO SO COULD RESULT IN SERIOUS INJURY AND/OR DEATH.

 **WARNING**

BEFORE SERVICING THE DOCK LEVELER, ALWAYS POSITION TRAFFIC CONES OR A BARRICADE BEHIND THE DOCK LEVELER. ALSO POSITION CONES OR BARRICADES IN FRONT OF THE LEVELER TO WARN AGAINST VEHICLE TRAFFIC.

- * ALWAYS NOTIFY A FOREMAN OR SUPERVISOR THAT YOU ARE WORKING UNDER THE EQUIPMENT.
- * ALWAYS MAKE SURE THAT THE MAINTENANCE STRUT IS IN POSITION BEFORE WORKING UNDER THE LEVELER.
- * ALWAYS MAKE SURE THAT THE OVERHEAD DOOR IS SECURELY HELD IN THE RAISED POSITION.

SERVICE AND MAINTENANCE

PIONEER recommends periodic inspection and servicing of the “P2000” Series mechanical leveler to assure proper operation and maximum life span of the dock leveler. Units should be inspected a minimum of every six months, and if needed, (See “OPERATING INSTRUCTIONS”, Page 2-1), can be adjusted and lubricated. Contact your local PIONEER dealer to secure a complete maintenance plan.

“P2000”

PARTS LIST

ITEM	DESCRIPTION
1	LIP PLATE ASSEMBLY 16”
2	HINGE PIN-LIP
4	MAIN SPRING
5	RATCHET PULL CHAIN ASSEMBLY
18	RATCHET MOUNTING ASSEMBLY UPPER
23	SAFETY LEG & MOUNTING ASSEMBLY
24	SAFETY LEG CHAIN ASSEMBLY
25	LIP LOCK ASSEMBLY
26	ROLL PINS
27	LIP ASSIST ASSEM. (STANDARD ON 18” & 20” LIP)

**OPTIONAL KITS
(FIELD INSTALLED)**

ITEM	DESCRIPTION
27	LIP ASSIST ASSEM. (OPTIONAL ON 16” LIP)
29	SHOCK ABSORBER
30	HYDRA LIP KIT
31	FULL RANGE TOES GUARDS (SET)
	WEATHER SEAL KIT 6’
	WEATHER SEAL KIT 8’
	WEATHER SEAL KIT 10’

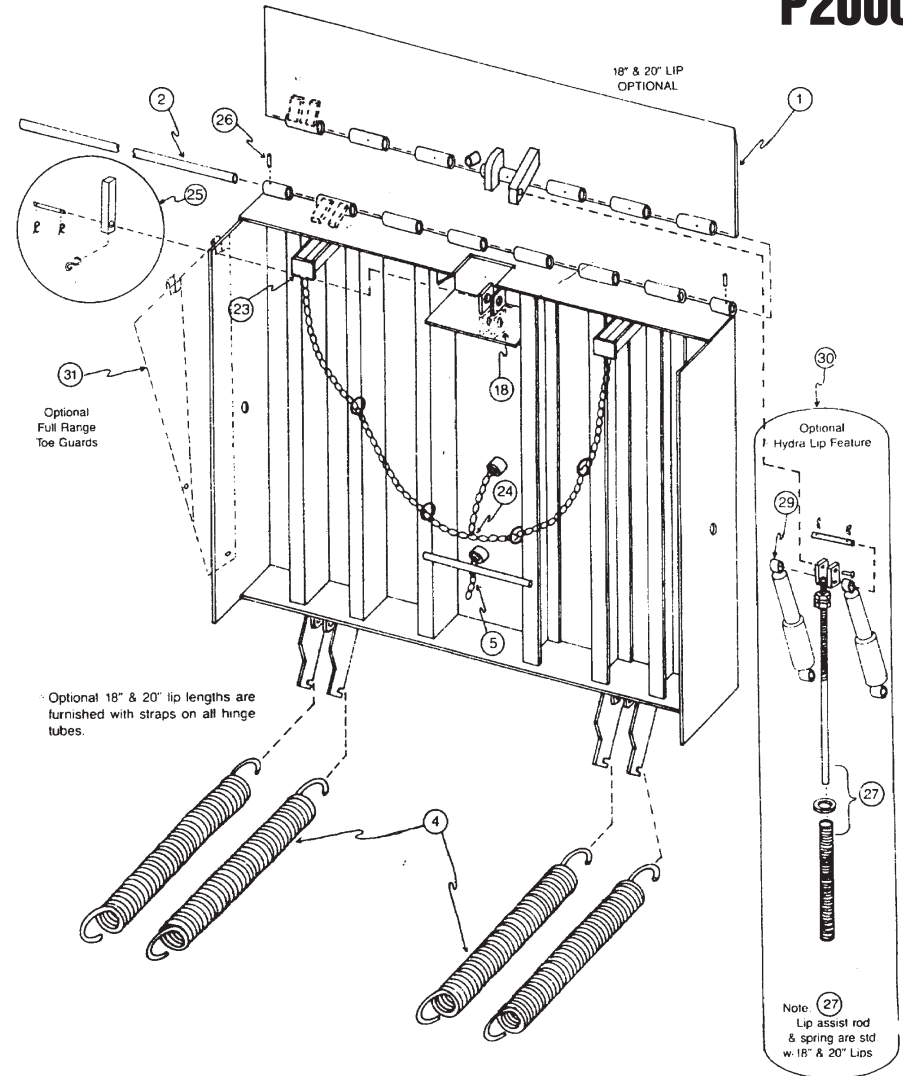

“P2000”

PARTS LIST	
ITEM	DESCRIPTION
3	DECK REAR HINGE KIT (SET)
6	SNUBBER CHAIN ASSEMBLY (For standard 16” Lip)
7	ADJUSTING ROD ASSEMBLY
8	WING NUT ASSEMBLY
9	RATCHET ASSEMBLY
19	RATCHET MOUNTING ASSEMBLY LOWER
20	SNUBBER SPRING
21	SNUBBER CHAIN TENSION SPRING
22	LIP LOCK SPRING
28	“S” HOOK

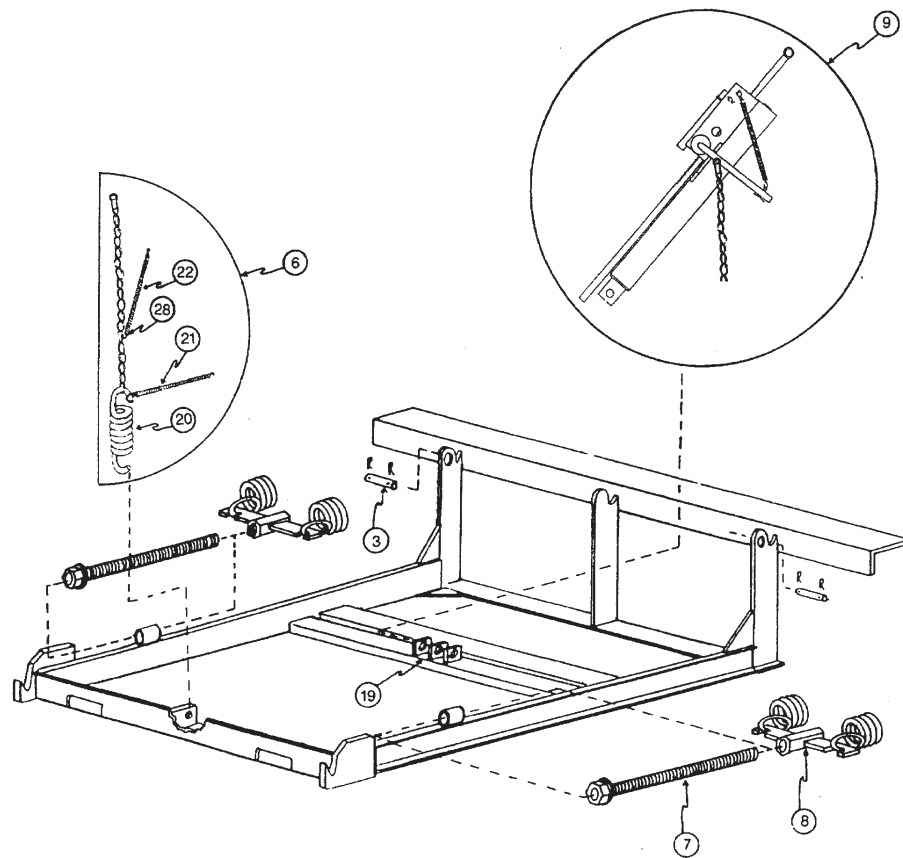



Warranty Procedure

The information on the Warranty Claim Request Form must be provided with all warranty claims.

When a call is received with a warranty problem a Customer Service number (CSF ####) will be issued for that problem only and cannot be used again without prior approval. This number must be on all invoices submitted for payment and on all correspondence.

Before and after pictures of all the work performed must be supplied with each claim. If you take digital pictures, e-mail them to warranty@pioneerleveler.com. If you use a film camera, forward the film to Pioneer Loading Dock Equipment, PO Box 338 Spring Hill, TN 37174, Attn: Warranty Dept.

No claim will be considered for processing without the required information.

Replacement Part under Warranty

Any replacement parts will be invoiced at the time of shipment. Credit will be given when the damaged parts are returned to Pioneer. Any exceptions will be determined by Pioneer. At Pioneer's discretion, replacement parts will be shipped either UPS ground or OTR truck. Any other requested method of shipment will be charged to the dealer. (i.e. UPS next day-Fed-Ex., etc.)

All returned parts will be issued a Return Authorization Number (RGA #####). a form will be faxed with the RGA number. A signed copy is to be faxed to 1-931-486-0316 and returned with the parts. The Return Authorization is good for 30 days. The RGA# must be listed on all returns, using the RGA Form as a packing list.

No credits will be issued without prior proper authorization.

A copy of the credit memo will be sent to your billing address. The credit will be given against the invoice issued for the replacement parts. Credits will be limited to repair parts, labor, and shipping fees directly related to warranty failures. No Credit will be given on non-Pioneer parts.

Any questions regarding Warranty or Return Authorization should be directed to Customer Service at warranty@pioneerleveler.com or 1-866-728-6195.

WARRANTY

PIONEER Manufacturing, Inc. guarantees its “P2000” Series dock levelers to be free from defects in materials and workmanship for a period of three (3) years on structural assembly and main springs and one (1) year (365 days) on miscellaneous parts from date of shipment.

A claim for breach of warranty will be honored if the product has been properly installed, maintained and operated within its rated capacity, and not damaged by abuse. Warranty does not cover damage by freight companies. Notify carrier within 15 days of receipt of merchandise and file a claim for hidden damage.

PIONEER reserves the right to either repair or replace any defective parts, and will accept full responsibility for the cost of labor, materials and freight for such repairs. Pioneer's standard warranty procedures must be followed.

PIONEER MANUFACTURING, INC. SHALL NOT BE LIABLE FOR LOSS OF USE OF ANY EQUIPMENT OR INCIDENTAL DAMAGES.

PIONEER EXPRESSLY DISCLAIMS ANY AND ALL IMPLIED WARRANTIES.

All PIONEER products meet or exceed Federal Occupational Safety and Health Act Standards, Commercial Standards 202-56, and American Society of Mechanical Engineers Specifications ANSI MH14. 1-84.

Warranty Phone: 1-866-228-6195